

June 29-July 4, 2008

[www.acoustics08-paris.org](http://www.acoustics08-paris.org)

*euronoise*

## Sound diffraction in periodic surfaces in ancient architectural structures

J.A. Cruz Calleja

Instituto Politécnico Nacional, Av Santa Ana No. 1000 col. San Francisco Culhuacan, Del Coyoacan, 04430 México, Mexico  
jorgeacruz@hotmail.com

In this work is analyzed the sound diffraction in architectural structures caused by periodic surfaces. It is studied the sound interaction with architectural structures using different types of sources, materials and sizes. The apparently scattering effect of the staircases in ancient constructions (Kukulcan's pyramid staircase in Chichen Itza), the speech communication to large distances and the spatial filter effect using the glide repetition pitch theory are also analyzed. Is the Chirp echo of the ancient prehispanic pyramids an intentional effect? Computational models of the phenomenon and real measurements were used to establish the phenomena physics principles.

## 1. Introduction

The acoustic diffraction in the pyramid of Kukulcan has been analyzed by Lubman, Declercq, Beristain and Bilsen.

In 2007 N. Tsingos exposed a geometrical model of the scattering in the staircase Kukulcan pyramid staircase. The model allows verify the spatial filter effect of the staircase and the diffraction curves formation. In the same form the model is capable to generate a sound rendering of the echo, but do not explain the phenomena.

Some theories have been exposed to explain the phenomenon and some questions have been exposed. New in situ experiments and mathematical model of the diffraction effect in ancient structures has allowed verify the validity of the models.

## 2. Echo physics principle

An echo caused by a flat surface when a sound impulse is generated in front, it is a repetition of the original event delayed in time and with minor intensity. In the flutter echo the continuous repetition of the impulse is present.

In a periodic surface the echo generated in front is created by continuous repetition of the original impulse generated by the reflections on the staircase steps. The initial reflection is caused by the first step and the final by the last step. These sound reflections create constructive or destructive interference caused by the phase changes of the sound signals, originated by time delay present in each reflection.

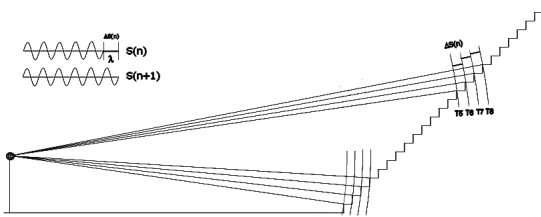

Fig.1 Interaction of the reflections in a periodic surface.

## 3. Chirp echo parameters

Diverse parameters are involved in the echo formation which modifies the echo length, the present diffraction frequencies and the upper - lower frequency diffraction limits.

### 3.1. Sound source position

Some chirp echo characteristics depend of sound source position. The sound source height modify the arrival time of the echo and the lines diffraction curvature.

The distance of the sound source to the staircase modifies the arrival time echo and diffraction frequencies. When the sound source is join staircase the diffraction is not present at all.

The possible trajectories that can cross the sound to be received by the observer are indicated in figure 1.

- 1 The sound that travels directly to the pyramid and is received directly.
- 2 The sound that travels directly to the pyramid and is received after to have reflected in the ground.
- 3 The sound that is reflected in the ground before traveling to the pyramid and that is received directly.
- 4 The sound that has been reflected in the ground before traveling to the pyramid and that is received after to have reflected in the same one.

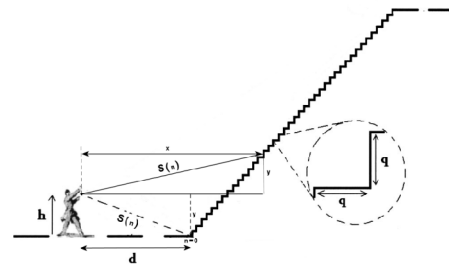

Fig.2 Pyramid's staircase and sound paths description.

Using a modification of the glide repetition pitch theory, the function that allows to calculate the correct trajectories  $S(n)$  that originates the reflected rays in the staircase for the consideration number one is:

$$S(n) = \sqrt{x^2 + y^2} \quad (1)$$

For steps with different wide and height the expression is:

$$S(n) = \sqrt{(d + (n \cdot q_x))^2 + (((n+1) \cdot q_y) - h)^2} \quad (2)$$

Being

$q_x$ = Wide of the step

$q_y$ = Heigh of the step

For this case, we use the next expression:

$$S(n) = \sqrt{(d + (n \cdot q))^2 + (((n+1) \cdot q) - h)^2} \quad (3)$$

Being  $n$  the step number and its first value is cero.

The mathematical equation that allows calculating the present frequencies in this landslide it is deduced by the following way.

The increase in distance between trajectories of two successive reflections is given by:

$$\Delta S(n) = S(n+1) - S(n) \quad (4)$$

$$S(n+1) = \Delta S(n) + S(n) \quad (5)$$

The increase of the distance is equal to the wavelength for a given reflection.

$$\Delta S(n) = \lambda(n) \quad (6)$$

The time that would take a wave travel this increase of distance is given by:

$$T = \frac{\lambda}{c} \quad \therefore \quad \tau(n) = \frac{\Delta S(n)}{c} \quad (7)$$

The distance increment is not constant so the difference between two successive increases of distance is given by:

$$\Delta S(n) = \Delta_{n+1}S(n) - \Delta_n S(n) \quad (8)$$

The sum of the increases is equal to the total variation of the wavelength.

$$\sum \Delta S(n) = \Delta \lambda \quad (9)$$

$$\Delta \lambda = \frac{c}{f_f} - \frac{c}{f_i} = \lambda_f - \lambda_i \quad (10)$$

$$\Delta f = f_f - f_i \quad (11)$$

In order to calculate the frequency  $f(n)$  is used the following procedure:

$$c = \frac{\lambda}{T} \quad (12)$$

$$T = \frac{\lambda}{c} \quad \therefore \quad f = \frac{c}{\lambda} \quad (13)$$

and

$$f(n) = \frac{c}{\Delta S(n)} \quad (14)$$

$$f(n) = \frac{c}{2S_{(n+1)} - 2S_{(n)}} \quad (15)$$

The final expression which allows calculating the frequency for a step n is:

$$f(n) = m \cdot \frac{171.5}{\left[ \sqrt{(d + ((n+1) \cdot q))^2 + ((n+2) \cdot q) - h)^2} - \sqrt{(d + (n \cdot q))^2 + ((n+1) \cdot q) - h)^2} \right]} \quad (16)$$

Being m is the harmonic number

We can calculate of  $S(n)$  using the following considerations.

The reflected angle of reflected ray is given by:

$$\theta = \arctan \frac{y}{x} \quad (17)$$

then

$$\theta = \arctan \frac{((n+1) \cdot q) - h}{(n \cdot q) + d} \quad (18)$$

The ray path is given by:

$$S(n) = \frac{x}{\cos \theta} \quad (19)$$

$$S(n) = \frac{(n \cdot q) + d}{\cos \left( \arctan \frac{((n+1) \cdot q) - h}{(n \cdot q) + d} \right)} \quad (20)$$

Therefore, being  $c=343$  frequency  $f(n)$  is calculated by:

$$f(n) = m \cdot \frac{171.5}{\left[ \frac{((n+1) \cdot q) + d}{\cos \left( \arctan \frac{((n+2) \cdot q) - h}{((n+1) \cdot q) + d} \right)} - \frac{(n \cdot q) + d}{\cos \left( \arctan \frac{((n+1) \cdot q) - h}{(n \cdot q) + d} \right)} \right]} \quad (21)$$

### 3.1.1. Distance and height

The resulting echo of the diffraction process is function of the distance and height which the impulse is emitted. The sonorous source position changes the  $S(n)$  trajectories, therefore the diffraction frequencies.

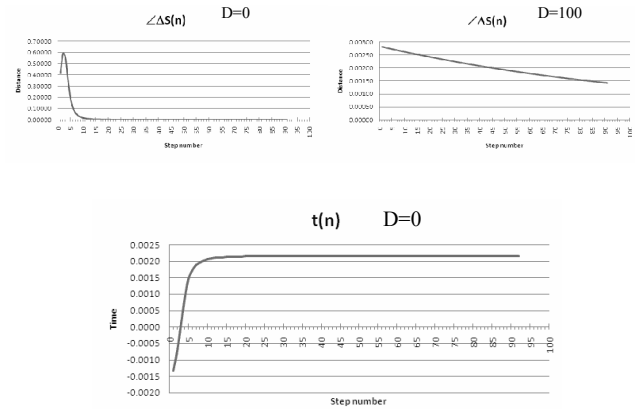

Fig.3 Variation of  $\Delta S(n)$  and  $t(n)$ .

To distances very near staircase increase of  $\Delta S(n)$  tends very quickly to zero (see Fig. 3), reason why the diffraction of the sound waves is little perceivable. When the distance of the sonorous source to the staircase is great, the increase of  $\Delta S(n)$  tends slowly to zero and the change of  $f(n)$  is smooth; the diffraction of the sound waves is clearly appreciable.

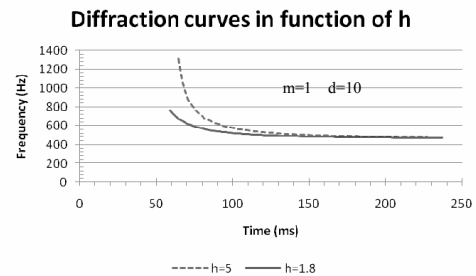

Fig.4 Variation of diffraction curves with height.

The height of the source also this involved in the formation of the echo; when the height of the sonorous source is increased, the trajectories of sonorous rays for lower steps are increased, and for the superior ones are diminish and the initials values of  $f(n)$  are increased.

### 3.2. Impulse characteristics

#### 3.2.1. Impulse length

The sound used to produce the echo must be an impulse with smaller duration to  $2d/c$ , in where d is the distance of the sound source to the first step and c the sound velocity. This condition avoids an interaction between the incident wave and the reflected wave, and allows to receive the sequence of originated steps reflections with its respective delay of time, in such a way it can be formed and be caught the frequency slide. If the sound used is greater or continuous, there would be an interaction between the incident wave and the reflected wave, which would prevent to notice the frequency landslide and the effect of space filter caused by the diffraction of the waves in the staircase is present as a comb filter.

### 3.2.2. Type sonorous source

Commonly a handclap has been used to generate the echo in the pyramid of Kukulcan. Using others excitation source types the echo generated is different. Playing different Pre-Hispanic instruments in front of the stairs of the Kukulcan pyramid, was verified the relation existent between the frequencies present in the echo and the impulse generated by one sound source [2]. The sonograms clearly show that the frequencies are determined by the type of sound source. So the chirp echo can be produced when the sound source generates an impulsive sound.

### 3.3. Periodic surface proprieties

#### 3.3.1. Material proprieties

The limestone properties are described by Declercq; the limestone staircase of Kukulcan's pyramid has a density of 2000 kg/m<sup>3</sup>, the velocity of the longitudinal wave is 4100 m/s and 2300 m/s for the shear wave velocity. This data have to be verified using a limestone sample. The sound intensity for an audible sound is minor that an ultrasonic wave, so the interaction between the sound beam and solid periodic surface is small.

#### 3.3.2. Influence of the ground

In this section it is analyzed the possible influence of the ground in front of the pyramid in the echo formation. The trajectories for the points 2, 3 and 4 of the section 3.1 are calculated in this part.

The ground in front of the staircase allows a part of the sonorous signal be reflected toward the staircase. The angle  $\alpha$  that would allow a ray reflected in the ground goes to the last step of the staircase can be calculated with the following expression:

$$\alpha_{r, \max} = \arctan \left( \frac{H+h}{D+d} \right) \quad (22)$$

For smaller angles  $\alpha$  the sound wave is reflected in the direction of the staircase.

$$x_i = \frac{h}{\tan \alpha} \quad (23)$$

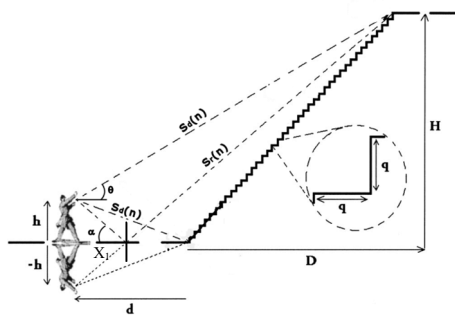

Fig.5 Ground reflected sound paths.

The trajectory for a ray reflected in the ground and reflected in a step "n" is given by:

$$S_r(n) = \frac{x}{\cos \alpha} \quad (24)$$

For a given reflection:

$$\alpha = \arctan \left( \frac{(n+1) \cdot q + h}{(n \cdot q) + d} \right) \quad (25)$$

then

$$S_r(n) = \frac{(n \cdot q) + d}{\cos \left[ \arctan \left( \frac{(n+1) \cdot q + h}{(n \cdot q) + d} \right) \right]} \quad (26)$$

or

$$S_r(n) = \sqrt{(d + (n \cdot q))^2 + (((n+1) \cdot q) + h)^2} \quad (27)$$

In order to calculate the trajectories that fulfill the conditions of point 2 and 3 we have:

$$f(n) = m \cdot \frac{c}{\frac{\cos \left[ \arctan \left( \frac{(n+1) \cdot q + h}{(n \cdot q) + d} \right) \right]}{\cos \left[ \arctan \left( \frac{(n+2) \cdot q + h}{(n \cdot q) + d} \right) \right]} + \frac{\cos \left[ \arctan \left( \frac{(n+1) \cdot q + h}{(n \cdot q) + d} \right) \right]}{\cos \left[ \arctan \left( \frac{(n+2) \cdot q + h}{(n \cdot q) + d} \right) \right]}} \quad (28)$$

For the conditions established in point 4:

$$f(n) = m \cdot \frac{c}{2 \left[ \frac{\cos \left[ \arctan \left( \frac{(n+1) \cdot q + h}{(n \cdot q) + d} \right) \right]}{\cos \left[ \arctan \left( \frac{(n+2) \cdot q + h}{(n \cdot q) + d} \right) \right]} - \frac{\cos \left[ \arctan \left( \frac{(n+1) \cdot q + h}{(n \cdot q) + d} \right) \right]}{\cos \left[ \arctan \left( \frac{(n+2) \cdot q + h}{(n \cdot q) + d} \right) \right]} \right]} \quad (29)$$

#### 3.3.3. Influence of the z axis

We can expand the glide repetition pitch theory to three dimensions adding the possible displacement of the sonorous ray throughout the staircase (z-axis). The expression that allows calculating the trajectories for sonorous rays is:

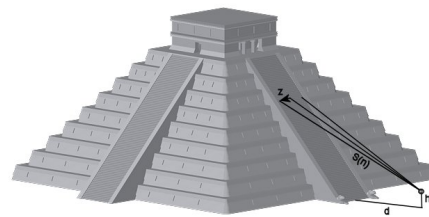

Fig.7 Diagram to calculate de z axis

$$S(n) = \sqrt{x^2 + y^2 + z^2} \quad (30)$$

For our case:

$$S(n) = \sqrt{(d + (n \cdot q))^2 + (((n+1) \cdot q) - h)^2 + z^2} \quad (31)$$

The values of z are limited by the wide of the staircase (9m length) and go from 0 to 4,5 and from 0 to -4,5, taking the value zero the central point from the same one. The variation of S(n) in function of z for the case of the pyramid of Kukulcan is small, for this reason the variation of f(n) is also small.

In Fig. 6 the diffraction curves for the different values from "z" appear very next to those of the central value (z=0). This could explain so that the curved presents in sonograms of the real sound do not appear as thin lines, else have a determined thickness, for this reason the curves of diffraction for the possible values of z are present in it

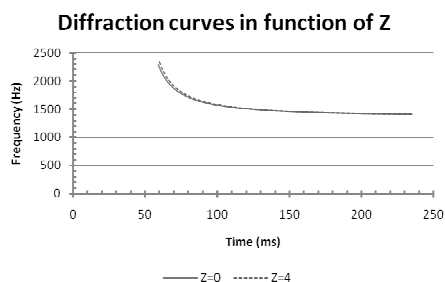

Fig.6 Echo in function of the steps number. (m=1)

### 3.3.4. Number of steps

The number of the steps contained in the periodic surface changes the echo length. If the staircase has a lot of steps the echo length will be great. By other side if the staircase has little steps the echo length will be short. The echo length is dependent of the number of steps

### 3.3.5. Steps dimension

The generated echo is caused by the combination of diffraction, dispersion and reflection of the sound.

For diffracted waves the limits are established by:

$$\frac{2c}{q} \geq f_d \geq \frac{c}{2D} \tag{32}$$

Specular reflected waves

$$f_s > \frac{2c}{q} \tag{33}$$

being  $q$ = surface periodicity and  $D$ = distance between the center of two steps

Considering the steps as a line array of radiating sources the minimum frequency that can be diffracted by the staircase based on the dimensions of the steps, and this given by:

$$f_d \geq \frac{c}{2d} \tag{34}$$

$d$ = distance between the sound sources

For smaller frequencies to  $f_d$  the waves are added in coherent form and the diffraction is not possible absolutely, because the wavelength of the involved frequencies is bigger than frequency slide (its equivalent wavelength), so this small distance does not allow its cancellation by destructive interference, being the produced reflection similar to the produced by a flat surface.

For high frequencies, in which the involved wavelength is small in comparison with the dimensions of the step, the reflections produced are specular, reason why the sound waves are governed by the laws of the geometric acoustics. Besides, high frequencies suffer attenuation due to the air absorption.

## 3.4. Medium of transmission

The air humidity and the temperature have an effect on the sound velocity. The humid Yucatan air have a density of  $\rho=1.1466 \text{ kg/m}^3$  and the sound velocity has been taken as  $c=343 \text{ m/s}$  [1]. In the calculus were taken the previous values which have to be verified in situ.

## 4. Numerical results

In order to demonstrate the influence of the parameters involved in the echo formation were realized some experiments in situ using Bruel & kjaer equipment and hi quality recordings; the recordings were made in 32 bits resolution and were analyzed using computational software. The sonograms were made using a Blackman Harris Window with 1024 size.

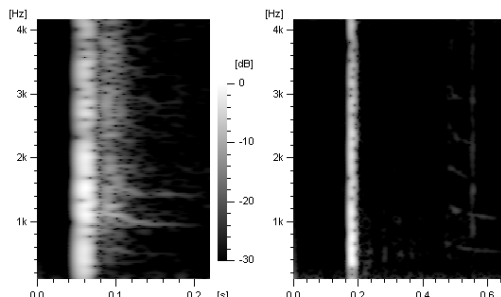

Fig.9 Chirp echo in function of the distance. Sonograms of an echo recorded at 5 and 50 meters respectively.

The influence of the sound source position was demonstrated in a theoretical way. This influence can be demonstrated in a practical way analyzing the echo recordings toke in different points in front of the pyramid. The ground effect is supported with the thickness present in diffraction curves. This explains why the diffraction curves are not thin lines in the real echo.

Using Fig.9 it is possible to demonstrate the curvature change of the diffraction slide in function of the distance. When the distance is great the frequency slide is flatter.

Measured value		Calculated value		h=1.5m
Arrival time	Echo Length	Arrival time	Echo Length	Distance
0.029	0.152	0.029s	0.184	5m
0.057	0.179	0.058s	0.179	10m
0.291	0.159	0.291s	0.158	50m
0.348	0.156	0.349s	0.156	60m

Table 1 Arrival and length times for an impulse generated in front of the Kukulcan’s pyramid at different distances

The time arrival and echo length in function of sound source distance to the staircase is verified in Table1.

The influence of the step size was verified in an experimental way in different ancient structures; for the Kukulcan and Moon (Teotihuacan) pyramids were calculated and measured the limit values for diffracted waves. In Fig. 10 it is possible to observe the frequency limits for two ancient periodic surfaces.

The number of the steps affects the echo length. Generating an impulse in front of a Venus temple (Small pyramid 14 steps) it was possible demonstrate this fact. See Fig. 11.

The frequencies contained in the chirp echo are dependent of the sound source characteristics. Using an adequate MLS signal (0.34s length) the chirp echo was generated al 20 meters. In Fig. 11 it is possible to observe the frequency limits calculated.

$\frac{2c}{q}$	$\geq f_d \geq$	$\frac{c}{2D}$	q(m)	D(m)
2608.36Hz	Chichen Itza	461.09 Hz	0.263	0.3719
2302.01Hz	Teotihuacan	406.94Hz	0.298	0.4214

Table 2 Frequency limits for diffracted waves in two ancient pyramids

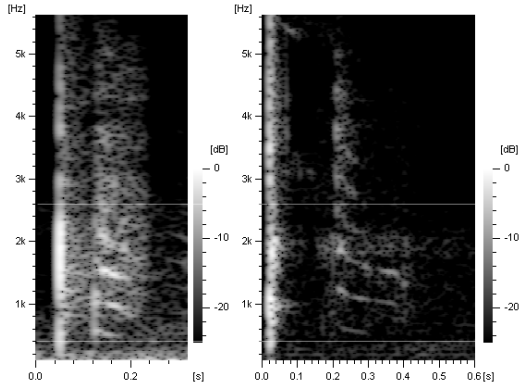

Fig.10 Sonograms of Moon and kukulcan pyramids. The lines help us to mark the upper and lower frequency limits. At 10 meters the maximum duration of the impulse will have to be 59ms to avoid an interaction between the incident wave and the reflected wave. Using a continuous pink noise source in front to the staircase of pyramid of Kukulcan, the comb filter is produced. When a pure frequency or narrow band noise is generated in front of the staircase, the generated chirp echo only contains the correspondent frequencies.

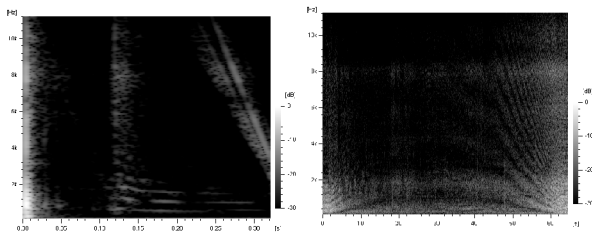

Fig.11 Echo generated with MLS signal. To the right interference caused by continuous noise source, in front of the Kukulcan pyramid.

## Conclusion

The validity of the proposed mathematical model based on the repetition pitch glide was verified. In the same form the involved parameters in the echo generation was analyzed and its influence in the echo formation was corroborated using some in situ experiments. The model calculates the arrival time, echo length and frequencies in a correct way.

Using this model it is possible to determinate that the chirp echo Lubman’s recording [6] was made at 23 meters approximately and not at 10 meters. In Fig. 12 is presented the real sonograms and the calculated diffraction curves, we can observe the correspondence between the calculated and the real curves. The Author’s recording was made at 10 meters of the Kukulcan’s staircase. This fact was verified experimentally.

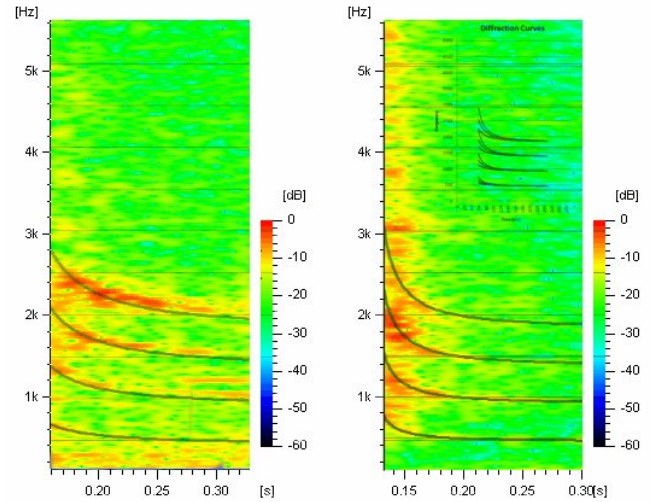

Fig.12 Sonograms of Lubman and J. Cruz echo recordings. In black lines the calculated diffraction curves (In frame the curves with ground effect); under the real echo sonograms.

## Acknowledgments

The author is thankful to INAH (Instituto Nacional de Antropología e Historia) by the offered support, with following students who assisted the recording of the studied sounds: Angelica Villanueva Almaraz, Jessica Mora Alcantar, to Professor Gerardo Hernandez Sucilla and the acoustics carrier students (8EM8). The author is also thankful to Nico F. Declercq by his invaluable support and advice.

## References

- [1] Declercq Nico F., “A theoretical study of special acoustic effects caused by the staircase of the El Castillo pyramid at the Maya ruins of Chichen-Itza in Mexico”, *Journal of the Acoustical Society of America* 116(6), 3328 -3335 (2004).
- [2] Cruz C. Jorge A., “Acoustic phenomena in archaeological zones in Mexico”, 19th International Congress on Acoustics, Madrid, España, 2-7 September 2007.
- [3] Sergio Beristáin, Cecilia Coss, Gabriela Aquino, and Jose Negrete, “Tonal response on the stairway of the main pyramid at La Ciudadela, Teotihuacan archaeological site”, *Journal of the Acoustical Society of America* 112, 2285 (2002).
- [4] Frans A. Bilsen, “Repetition Pitch glide from the step pyramid at Chichen Itza”, *Journal of the Acoustical Society of America* 120(2), 594 -596 (2006).
- [5] Tsingos, Nicolas; Lefebvre, Sylvain; Dachsbacher, Carsten; Dellepiane, Matteo, “Extending geometrical acoustics to highly detailed architectural environments”, 19th International Congress on Acoustics, Madrid, España, 2-7 September 2007.
- [6] David Lubman: <http://www.ocasa.org/MayanPyramid.htm> ~site visited on 12/13/2007.